

INSTALLATION INSTRUCTIONS

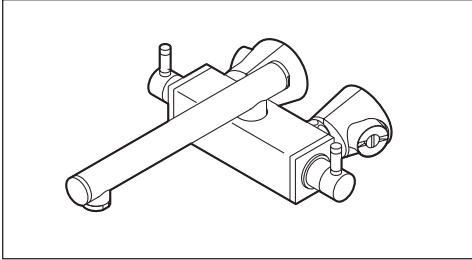

K2530-BW **TWO HANDLE** **Kitchen Faucet**

Tools

For safety and easy faucet replacement, San-Ei recommends the use of the following helpful tools:



SAFETY GLASSES



PIPE WRENCH



PLIERS



CHANNEL LOCKS



ADJUSTABLE WRENCH



BASIN WRENCH



PHILLIPS SCREWDRIVER



FLASHLIGHT

About This Manual

Keep Instructions for Future Reference

Thank you for purchasing San-Ei's quality faucet.

With simple care and maintenance, it will provide you with many years of reliable performance.

Please read instructions before installation.

TIPS FOR REMOVAL OF OLD FAUCET

CAUTION: Always turn water OFF before removing existing faucet or disassembling the faucet.

Open the faucet handles to relieve water pressure and ensure that complete water shut-off has been accomplished.

(Complies with ASME A112.18.1 and CSA B 125)

PARTS LIST

The structure shown is an illustration.

Please use this structure for better understanding.

Please ask the part of the selling agent or our company of purchase, in case that the pottery part cracked.

The standard color is White (JW).

The others become the production that receives.

As for the order, please attach the color number at the end of the article No.

Color Number	Name
JW	White
JL	Ivory
JG	Green
JD	Black

K2530-BW

General Description

1. Cap
2. Color Plate (Red)
3. Lever Cover
4. Lever
5. O-Ring
6. Handle
7. Color Plate B (Red)
8. Handle Cover
9. Upper Part of Ceramic Control
10. Side Cover Control
11. Ceramic Cartridge (L)
12. Color Plate (Blue)
13. Color Plate B (Blue)
14. Ceramic Cartridge (R)
15. Side Cover
16. Body
17. Body Cover
18. Rubber Washer
19. Nipple
20. Rubber Washer
21. Escutcheon Cover
22. Eccentric Link
23. Strainer Cap
24. Strainer
25. Spindle
26. Rubber Washer
27. Outlet Neck
28. Set Screw at Rod End
29. Outlet Neck Holder
30. Outlet Nipple
31. Outlet Neck Spacer
32. Outlet Cover Cap
33. Outlet Pipe Cover
34. Outlet Pipe
35. Outlet Cover Cap
36. Filter Nipple
37. Filter Spacer
38. Rubber Washer
39. Aerator
40. Aerator Body

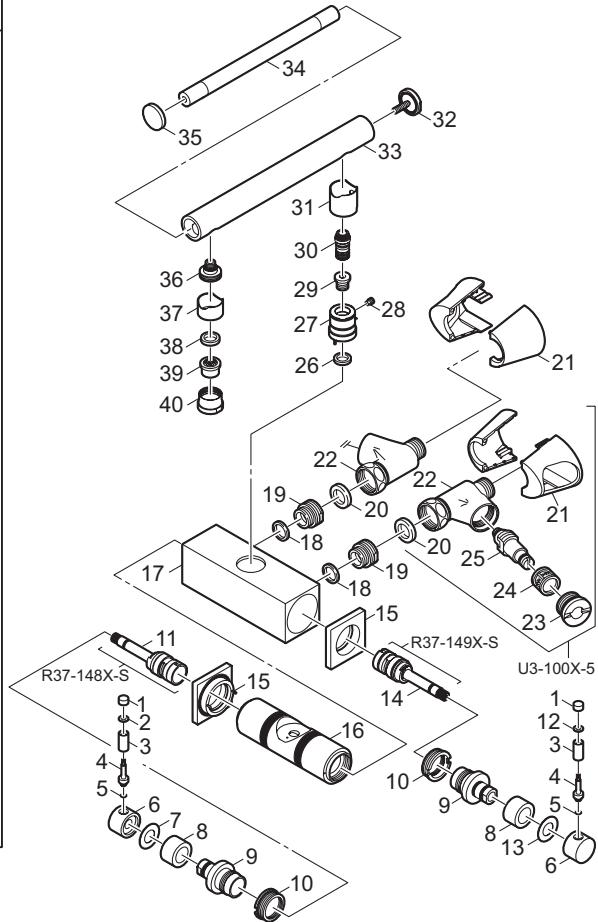

OPERATION

Installation guide

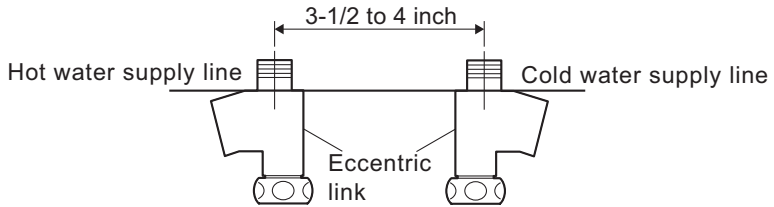

Installation Memo :

The distance between the center of eccentric link is from 3-1/2 to 4 inch.

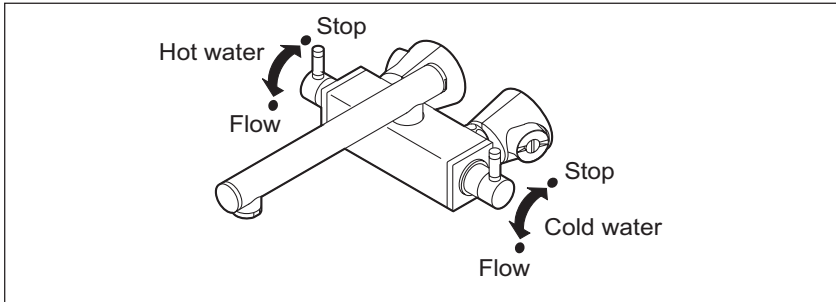

Important !

- * All plumbing is to be installed in accordance with applicable codes and regulations.
- * Flush all water lines prior to making connection.

INSTALL FAUCET

1 Be sure that dust inside water supply line is clean.

2 Remove escutcheon cover, by pushing circled two portion.

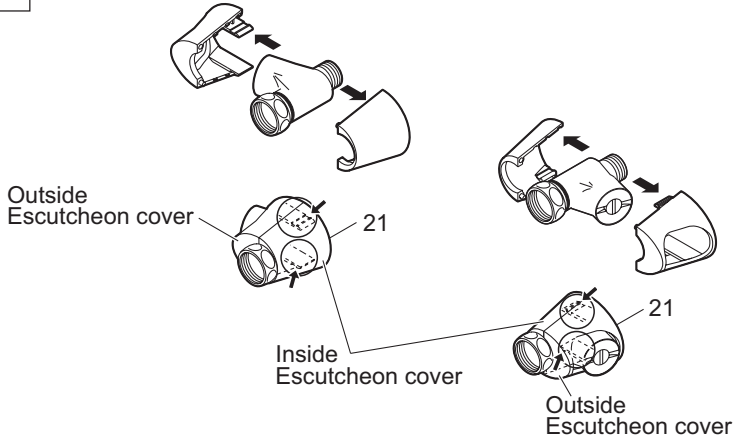

3 Teflon tape is wrapped 5 times onto the thread of eccentric links.

Note:

Wrapping direction should be clockwise.

Caution!

If teflon tape is wrapped unclockwise, it cause water leakage.

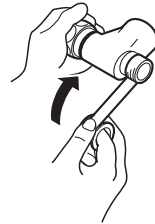

4 Install each eccentric links to water supply lines.

Be sure that the position of each eccentric links(22) are in parallel as shown in the figure.

Please do not loosen the eccentric link(22) in the opposite direction after the installation.

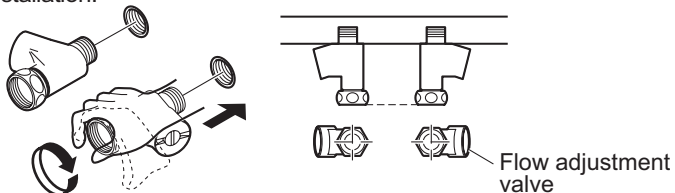

5

Install faucet body to eccentric link.

Please make sure that rubber washer(20) should be in place between faucet body and eccentric link(22).

Be sure that the position of each eccentric links(22) are in parallel as shown in the figure.

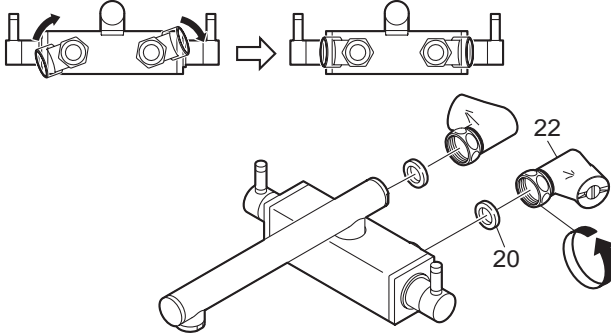

6

Make tightening the nut of eccentric link by wrench.

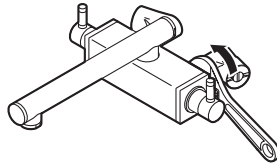

7

Put the escutcheon cover back onto eccentric link.

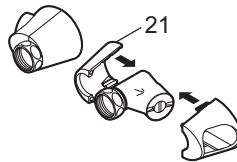

8

Please go to "Flushing Instruction" section before starting to use faucet.

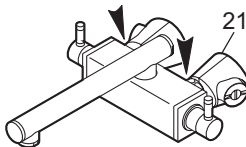

FLUSHING INSTRUCTIONS

IMPORTANT! : Pipe chips, sand, stones and other solid found in new and renovated plumbing can damage the sealing of the cartridge and cause leaks to avoid damage,

DO NOT TURN ON SUPPLY VALVES until instructed below.

1. After installing and connecting your new faucet, turn on in the full cold position (handle pointing to the right) and turn on the cold supply for 15 seconds.
2. Without closing the handle, turn to the full hot position (handle pointing to the left) and turn on the hot supply for 15 seconds.
3. Close the handle, then using a towel unscrew the aerator from the end of the spout and clean the aerator.
4. Using a towel replace the aerator and check the system for leaks.

TROUBLESHOOTING

TO CORRECT REVERSED HOT AND COLD POSITIONS :

1. Shut off both stop valves. Then, open faucet handles to relieve water pressure that complete water shut-off has been accomplished.
2. Loosen nut and remove supply lines. Re-connect each supply lines into different supply stop valves. (Excessive bending will cause leaking and damage to the lines.) Then, tighten each of supply lines.
3. Re-installing and connecting, turn on both cold and hot supply.
4. Turn on in the full position, make sure that the each positions keeps correct way & make sure any water leakage.

MAINTENANCE

Care and Cleaning of Chrome and Special Finishes

Do not use abrasive or chemical cleaners (including chlorine bleach) to clean faucets as they may dull the luster and attack the chrome or special decorative finishes.

Use **ONLY** soap and water, then wipe dry with clean cloth or towel.

While cleaning the bathroom tile, the faucet should be protected from any splattering of cleaner. Acids and cleaning fluids will discolor or remove chrome plating.

LIMITED WARRANTY

SAN-EI products have been manufactured under the highest standards of quality and workmanship, and warrants to the original consumer purchaser that its products are free of defects in material and workmanship.

1. Ceramic cartridges and PVD finishes carry a **limited lifetime warranty** to the **Original Consumer Purchaser** for as long as that consumer purchaser owns his/her/their home. All other parts are warranted for **2 years** after the date of purchase.

2. SAN-EI warrants to the **Commercial Purchaser** that their products, purchased for commercial, industrial or other business use, are free from defects of workmanship and materials for a period of **1 year** after the date of purchase.

All warranties are to the original purchaser and require presentation of original sales receipt.

Warranty is not transferable. ***During the warranty period, SAN-EI will, at its option, repair or replace any part or parts which have been determined to be defective if returned at purchaser's expense. This shall be the sole remedy available under this warranty. Defects or damage caused by the use of other than genuine SAN-EI parts are not covered by this warranty. Installation or any other labor charges associated with the repair or re-installation of SAN-EI products is not covered by this warranty.*** Damage due to improper installation, misuse, poor maintenance practices, accident, alcohol, or other organic solvents, or use in any manner contrary to the written instructions provided, whether done by contractor, service company, or end user, are excluded from this warranty. Some states, provinces and nations do not allow the exclusion or limitation of incidental or consequential damages, so the above limitations or exclusions may not apply to you. This warranty gives you specific legal rights and you may also have other rights which vary from state to state, province to province, nation to nation.

SAN-EI will advise you of the procedure to follow in making warranty claims. Simply write to explain the defect and include product instruction manual, along with original proof of purchase receipt showing the store name, address and date of purchase.

Be sure to include your name, address and telephone number.

USER INFORMATION

Faucets made of leaded brass alloys may contribute small amounts of lead to water that is allowed to stand in contact with the brass.

The amount of lead contributed by any faucet is highest when the faucet is new.

The following steps may reduce potential exposure to lead from faucets and other parts of the plumbing system.

*Always run the water for a few seconds prior to use for drinking or cooking.

*Use only cold water for drinking or cooking.

*If you wish to flush the entire plumbing system of water that has been standing in the pipes or other fittings.

Run the cold water until the temperature of the water drops, indicating water coming from the outside main.

*If you are concerned about lead in your water, have your water tested by a certified laboratory in your area.

CONTACT

In the United States and Canada, please kindly call our office number for answers to any product, installation, or warranty questions.

**- Importer / Master Distributor -
Sanicor International Corp.**

2116 South Grand Ave., Santa Ana, CA 92705

Tel : 714-540-1110 Fax : 714-540-1171

SANEI